



Installation and Operating Instructions

For Single Burner Outdoor BBQ Models Alpha and Bravo.

IMPORTANT: READ THIS DOCUMENT THOROUGHLY BEFORE USING YOUR SOVEREIGN BBQ.

IMPORTANT: REMOVE ALL PACKING MATERIAL AND LITERATURE FROM YOUR BBQ BEFORE ASSEMBLY, CONNECTION TO GAS AND USE.

Thank you and congratulations for choosing a quality Sovereign BBQ for all your cooking and entertainment needs. By following these Installation and Operating Instructions for safe and easy operation, you will enjoy many years of satisfying, trouble free outdoor cooking.

INSTALLATION

Product Dimensions and Gas Connection Position

Alpha BBQ: 600mm Long x 380mm Deep x 295mm High. The gas connection is located on the right hand end of the BBQ and is 35mm from the rear and 80mm from the bottom of the BBQ.

Bravo BBQ: 480mm Long x 350mm Deep x 240mm High. The gas connection is located on the right hand end of the BBQ and is 23mm from the rear and 43mm from the bottom of the BBQ.

Choosing a Location

This BBQ is for outdoor use only and should be placed in a well ventilated area. Take care to ensure that it is not placed UNDER or ABOVE any combustible surfaces. The sides of the BBQ should NEVER be closer than the following: minimum recommended distances from combustible materials - 100mm sides, 200mm front and rear, 50mm bottom, 1200mm above. Keep this BBQ away from flammable materials. Installation of appliance must be in accordance with AS5601 - 2004 / AG601 2002 requirements.

Should you intend to install your BBQ on a boat, Sovereign BBQs recommend (for optimum performance) that the BBQ be installed either across the transom or to the port side of your vessel. This ensures the air intake on the BBQ is not installed to windward (as it would be if mounted to Starboard), and will make for more enjoyable use of your appliance in heavy weather conditions.

This appliance shall only be used in an above ground open-air situation with natural ventilation, without stagnant areas, where gas leakage and products of combustion are rapidly dispersed by wind and natural convection.

Any enclosure in which the appliance is used shall comply with one of the following;

Sovereign BBQs & Grills Australia
Phone (Intl +61 7) 3382 0230 • Fax (Intl +61 7) 3382 0087
Web: www.sovereignbbqs.com • Email: sales@sovereignbbqs.com

Choosing a Location (Cont.....)

An enclosure with walls on all sides, but at least one permanent opening at ground level and no overhead cover.

Within a partial enclosure that includes an overhead cover and no more than two walls.

Within a partial enclosure that includes an overhead cover and no more than two walls, the following shall apply –

- (i) at least 25% of the total wall area is completely open; and
- (ii) at least 30% of the remaining wall area is open and unrestricted

In the case of balconies, at least 20% of the total of the side, back and front wall areas shall be and remain open and unrestricted.

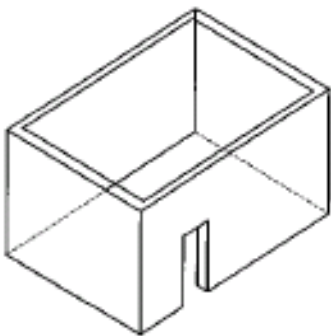

Figure F1 – Outdoor Area–Example 1

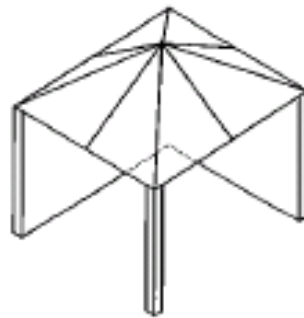

Figure F2 – Outdoor Area–Example 2

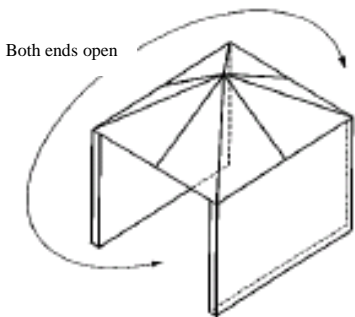
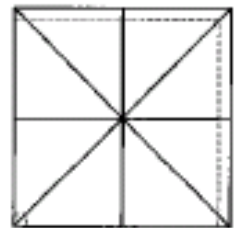

Figure F3 – Outdoor Area–Example 3

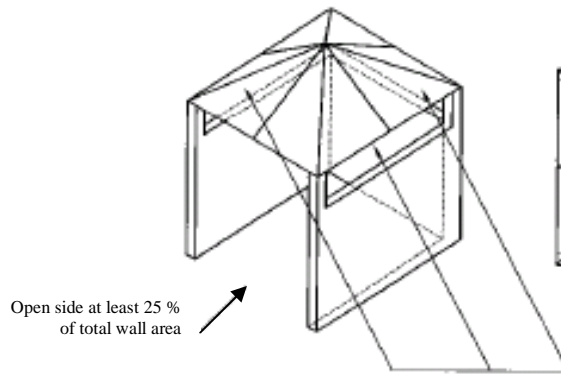
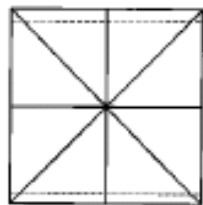
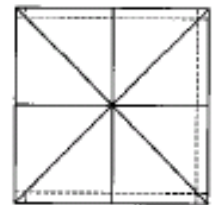

Figure F4 – Outdoor Area–Example 4



Open side at least 25 % of total wall area

30% or more in total of the remaining wall area is open and unrestricted

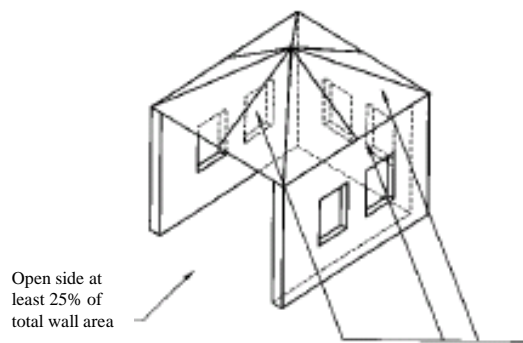
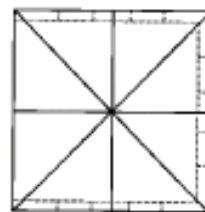

Figure F5 – Outdoor Area–Example 5



Open side at least 25% of total wall area

30% or more in total of the remaining wall area is open and unrestricted

Gas Supply Information

Your Sovereign BBQ is intended for connection to a reticulated gas supply (eg a gas system which supplies other appliances, including gas refrigerators and gas water heaters for example). A reticulated gas supply system should be supplied, installed and certified only by a qualified gas technician.

In the event that connecting your BBQ to a reticulated gas system is not preferred, please liaise with a qualified gas technician regarding suitable alternatives. If connecting your BBQ to a gas cylinder using a gas hose and regulator, only Class B or Class D gas hoses are suitable and the connection fitting is to be compatible with the BBQ gas inlet fitting described under the “Gas Connection” section in these Installation and Operating Instructions. Additionally, ensure the regulator is the correct type as described in the “Gas and Regulator Information” section in these Installation and Operating Instructions.

In any instance the gas technician is to complete the installation and test that the BBQ operates correctly and safely within accordance with these Installation and Operating Instructions and any governing regulations. The gas technician must also instruct the user on the correct and safe operation of the BBQ.

General Precautions

Do not obstruct any of the ventilation openings in your Sovereign BBQ body.

Should you need to disconnect the appliance from the gas supply point, confirm that the BBQ is turned off, and that there are no sources of ignition (cigarettes, open flame, sparks etc.) nearby before proceeding. Disconnect any hose from the gas supply point only, and not from the appliance itself.

If the appliance is installed using a hose, be sure to inspect the gas supply hose each time the BBQ is used and ensure it is free of any twisting or tension. The hose should hang freely with no bends, folds, or kinks, which could obstruct free flow of gas. Apart from the connection point, no part of the hose should touch any hot BBQ parts. Inspect the hose before each and every use of the appliance.

If the hose is damaged, it must be replaced with an approved hose to AS/NZS 1869 standards for use with LPG and meet the national standards for the country of use. The length shall not exceed 1.5m.

Gas and Regulator Information

WARNING: Your Sovereign BBQ **must be** connected to a gas supply that has passed via an approved (2.75kpa) regulator. If you are in doubt as to whether or not your gas supply source is low pressure (some balcony installations for example, where as gas connection point may have been provided), contact a qualified gas technician to ensure the gas supply source is suitable.

Please note your Sovereign BBQ is intended for use with either Propane Gas or ULPG (Refer to the data label on the left hand end of your BBQ for the correct gas type to use with your BBQ – your BBQ **cannot** be used with both gas types and is specifically configured for either Propane or ULPG applications. Approved regulators for use with your Sovereign BBQ must have an outlet pressure of 2.75 kpa. You must have an approved regulator in order for your BBQ to operate safely and efficiently. Please consult your local gas technician for advice should you have any queries.

Gas and Regulator Information (Cont.....)

The gas consumption of the Alpha BBQ is; Propane - 13.6Mj/h and ULPG – 9.5Mj/h.

The gas consumption of the Bravo BBQ is; propane - 11.0Mj/h and ULPG –8.0Mj/h.

The injector size of the Alpha BBQ is; Propane – 1.10mm and ULPG – 0.85mm.

The injector size of the Bravo BBQ is; Propane – 0.95mm and ULPG – 0.80mm.

For further information regarding the correct gas type and the gas consumption, please refer to the data plate on the left hand end of your selected Sovereign BBQ model.

Mounting Options

Your Sovereign BBQ can be mounted from the front, centre or rear using either standard or custom made fittings to suit your nominated installation location. As outlined above, Sovereign BBQs manufacture a range of standard mounting options for both rail and deck mounting marine installations. Some of these fittings may also be of use in other applications (such as at home or on your RV) These can be purchased with your chosen BBQ. They are as follows;

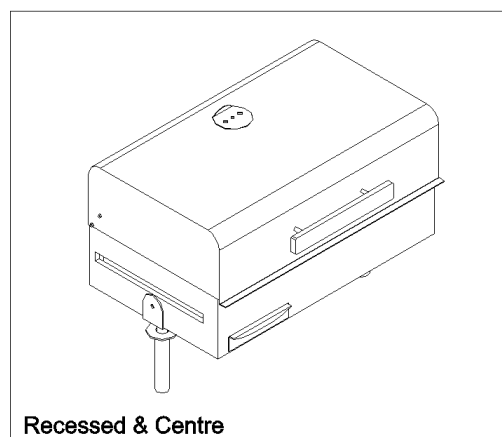
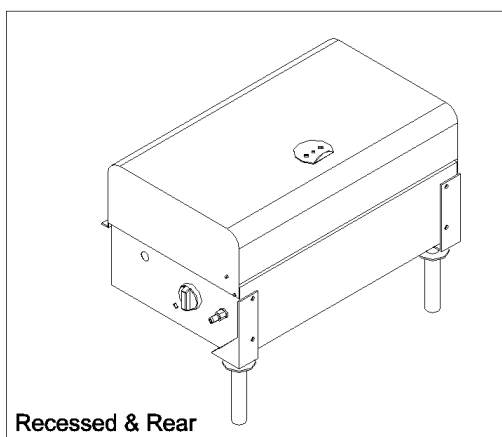
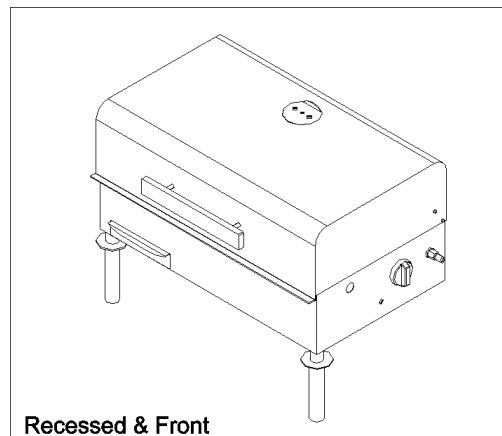
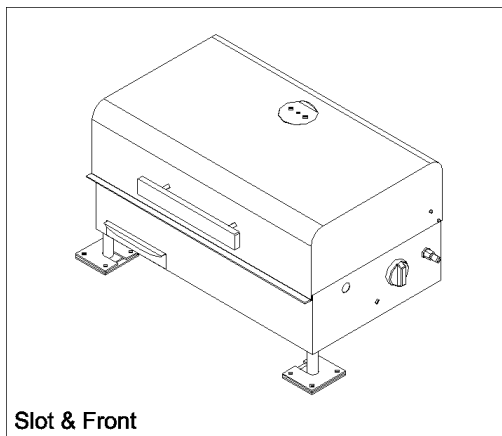

Mounting Options (Cont.....)

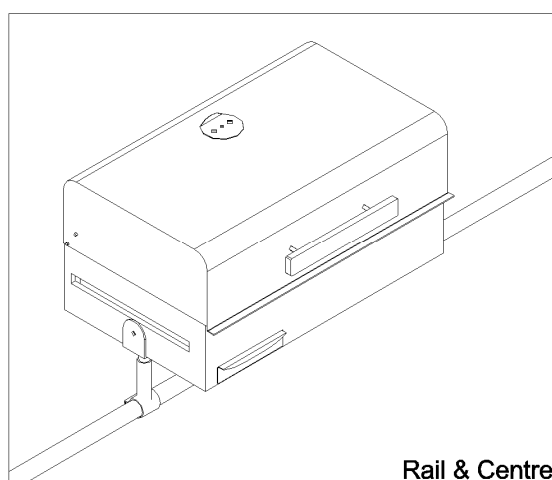
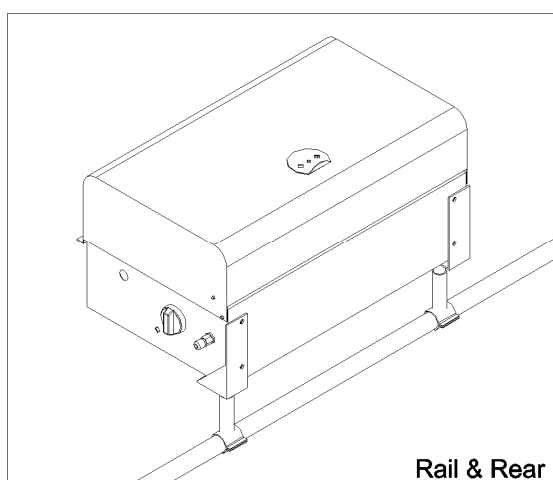
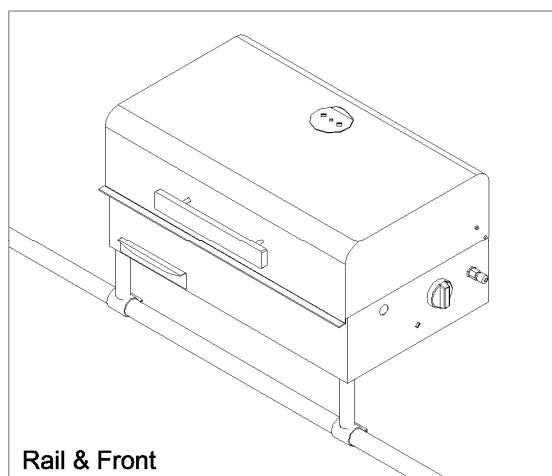

All front mounting options (whether rail or deck orientated) locate/slide into a dedicated recess at the front two (2) corners of your chosen Sovereign BBQ model (110mm in depth for the Bravo Model, and 140mm in depth for the Alpha Model). **For installation purposes, the front mounting centres for the Bravo Model are 394mm, whilst the Alpha Model is 523mm.** As for the standard centre and rear mounting options, they attach to your chosen Sovereign BBQ model via standard reinforced M10 (metric 10mm) threads located at the rear (two each side, installed vertically, making four threads in total across the back of your BBQ) and middle sides (one each side). The M10 threads are therefore also suitable for attaching custom made support/mounting brackets to suit any specific location/installation you may have.

Sovereign BBQs recommends that the installation position of your BBQ is both plumb and level (or at least as close as possible). This can be achieved in various ways including; levelling the standard mounting fittings when installed on a deck surface, trimming one of the two mounting options (one side) to correct any fall to one particular side, and or having your mounts (front, centre and rear) bent (in a machine) to correct any significant fall (based upon the unlevel surface to which the BBQ has to be installed upon, to meet your usage requirements). If in doubt, please do not hesitate to contact Sovereign BBQs for any technical assistance.

Mounting Options (Cont.....)

It is important to ensure that your chosen mounting position/location can comfortably sustain the weight of the BBQ (especially in the case of rail mounting your BBQ). If in doubt, Sovereign BBQs recommend supporting/bracing the BBQ with a Telescopic Rod. (Sovereign BBQs manufacture a standard adjustable length Telescopic Rod to suit most applications, or you can have a custom made brace manufactured to suit your specific requirements).

You will note that on the underside of all Sovereign BBQs, towards the rear, a telescopic rod attachment plate is provided to allow attachment of the telescopic rod (standard or custom) without any holes or penetrations needing to be made to the sealed bottom base compartment of your BBQ. To ensure the base compartment of the BBQ remains fully sealed (as designed), please use the attachment plate for any telescopic rod connection.

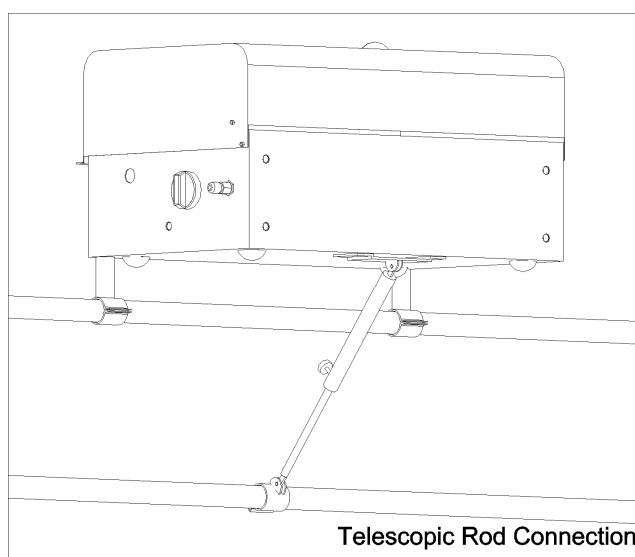

Gas Connection

The gas inlet fitting on your chosen Sovereign BBQ is a 1/4" male B.S.P. Parallel Inverted Flare fitting. The correct connection to the gas inlet fitting is to be made with a 1/4" B.S.P. Parallel Coned Swivel fitting.

After installation, your gas technician should proceed to check that there are no gas leaks by brushing a soapy water solution over the connection points on both the gas supply source and your Sovereign BBQ (do NOT use a naked flame). Any leaks should appear as bubbles. Retighten if necessary to ensure no gas leaks are present.

(To make soapy water solution, mix one part water and one part liquid detergent. Apply the mixture with a paint brush to all connections, and then turn the gas supply on at the supply point. Any connections that are not properly sealed should appear as bubbles.)

WARNING: After installation and prior to ignition of the BBQ for the first time, it is important that your gas technician checks the internal gas connections for leaks.

Gas Connection (Cont.....)

To check internal gas connections (Alpha and Bravo Models);

- (1) Remove the burner (refer to “Cleaning and Maintenance” section later in this document – the burner removal process varies per Sovereign BBQ Model).
- (2) Unscrew the 5 screws on the right hand side of the BBQ, loosening the protective plate.
- (3) Unscrew the brass thermocouple from the gas control valve, to allow the protective plate to be fully removed. Immediately **Refix** the thermocouple after the protective plate is removed, to complete the below outlined leak test. Brush over all connections with a soapy water solution, and then turn on the gas supply at the supply point. Any leaks should appear as bubbles. Retighten internal gas connections (on the control valve itself) if necessary. To retighten: (a) pull off the black control knob (b) unscrew the two external screws beside the control valve shaft (upon which the control knob is attached too) and also undo the external nut on the ¼ B.S.P. gas inlet – these fixings hold the control valve in place. (c) remove the gas control valve and gas piping from the BBQ (d) retighten and replace. Complete the process outlined in step (4) until no gas leaks are present, and then proceed to re-assemble the BBQ to its operating/assembled status (as follows).
- (4) Unscrew the brass thermocouple, to allow the protective plate to be reinstalled. Refix the thermocouple after the protective plate is placed loosely in position.
- (5) Tighten the five (5) screws that hold the protective plate in place, and then re-install the burner. As you have just removed the brass thermocouple to replace the protective plate, re-test the connection point (upon final completion of the re-assembly) where the thermocouple screws onto the gas control valve to ensure no leaks are present.

The below diagrams will assist with testing your Sovereign BBQ for any leaks.

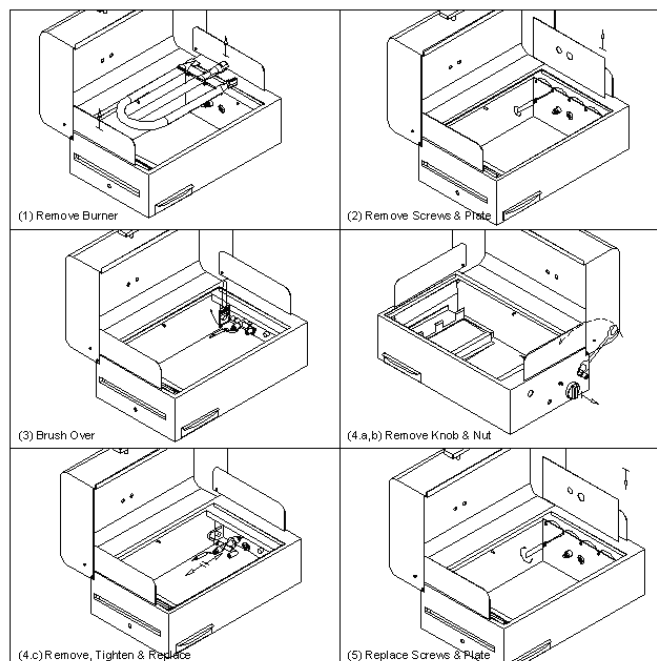

If the correct installation or performance cannot be obtained, contact Sovereign BBQs & Grills Australia.

Grill Kit

If you have purchased a Sovereign BBQ Flat/Grill model, your BBQ will have been supplied complete with a flame disperser. The flame disperser is designed to sit over the burner on the grill half of the plate, and below the BBQ plate itself (see below diagram). When the flame contacts the flame disperser, the flame disperser distributes the flame and heat evenly over the grilling surface. It is not recommended that you use your Flat/Grill Model Sovereign BBQ without the disperser installed.

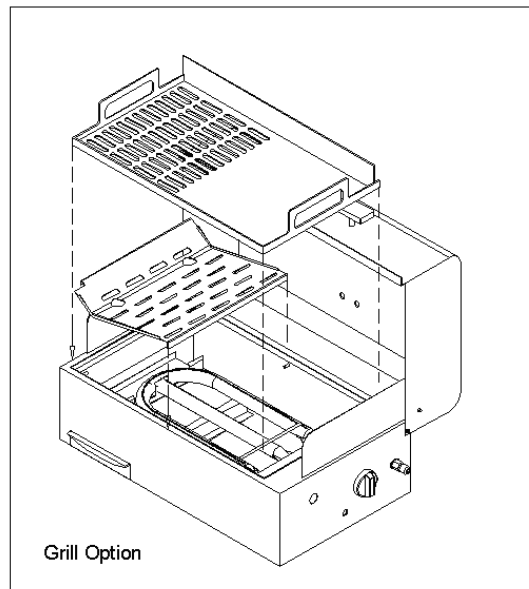

As the above diagram shows, the flame disperser clips in place on the left hand side of your Sovereign Flat/Grill BBQ, with the recessed/lowest part of the disperser (inclusive of larger drain holes) sitting over the fat tray (as shown above). Please ensure your disperser is installed in accordance with the above diagram.

USING YOUR SOVEREIGN BBQ

Lighting

- (1) Open the BBQ lid, on all occasions, prior to lighting.
- (2) The control knob should be in the OFF position.
- (3) Turn the gas on at the supply point to the BBQ.
- (4) To ignite - push the control knob in and turn it to the left (anti-clockwise). Repeat this action (the piezo ignition will make a clicking sound each time you do this) until the BBQ ignites, and then continue to hold the control knob in for at least 3 seconds until the flame failure valve (thermocouple) has engaged (depending upon various conditions, it may take more than 3 seconds for the flame failure valve to engage on occasion). To confirm ignition has occurred, and after ignition upon release of the control knob that the flame failure valve has engaged, a sight hole is provided beside the control valve.

The sight hole will allow you visually confirm the burner is alight (please use appropriate caution when lighting, including not looking directly into and/or too closely at the burner, through the sight hole) Once the flame failure valve has engaged after several seconds, you can then release the control knob and adjust the BBQ to your desired temperature (as per the low, medium and high heat settings as detailed on the side of your BBQ adjacent the control knob).

Lighting (Cont.....)

- (5) If ignition does not occur, turn the control knob to the OFF position and wait minimum 60 seconds before trying again.

The below diagrams will assist you in lighting your selected Sovereign BBQ.

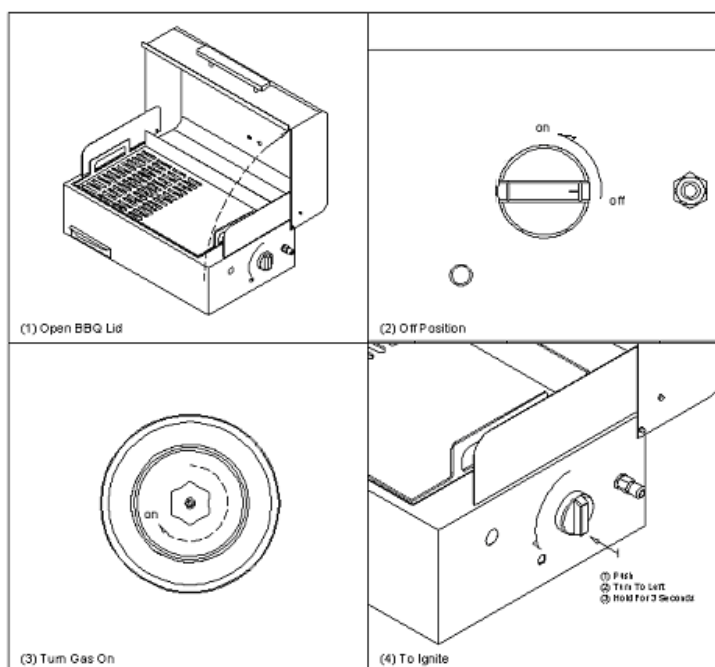

Optimum Cooking Temperatures

WARNING: always use the low temperature setting when cooking with the lid closed. The BBQ will reach much greater temperatures with the lid closed. Cooking time is also a lot quicker when cooking with the lid closed.

WARNING: prolonged periods of excessive temperatures may cause damage to your BBQ. The BBQ is designed to generate the required additional heat in adverse conditions such as wind and rain etc. However, generally a low setting is optimum for cooking in normal conditions.

WARNINGS

- (1) The outer shell of your BBQ will get hot during cooking.
- (2) Do not touch your BBQ during cooking, or after cooking, while the appliance is still hot.
- (3) The use of protective gloves is recommended when cooking or handling parts of your BBQ that are hot or in use.
- (4) Children should be supervised at all times around your BBQ.
- (5) Long hair and loose clothing should be tied back in case of unexpected flare-ups.
- (6) Do not leave your BBQ unattended while in use.
- (7) Do not place combustible materials near your BBQ.
- (8) Do not spray aerosols in the vicinity of your BBQ while in operation.
- (9) Your BBQ is not to be used as a space heater.

To Turn Off

- (1) Turn the control knob to the OFF position.
- (2) Always turn the gas supply off at the supply point as well.

CLEANING AND MAINTENANCE

BBQ Plate

Do not clean your BBQ while hot. Your BBQ plate can be easily removed using the handles on each side (as per the below diagram).

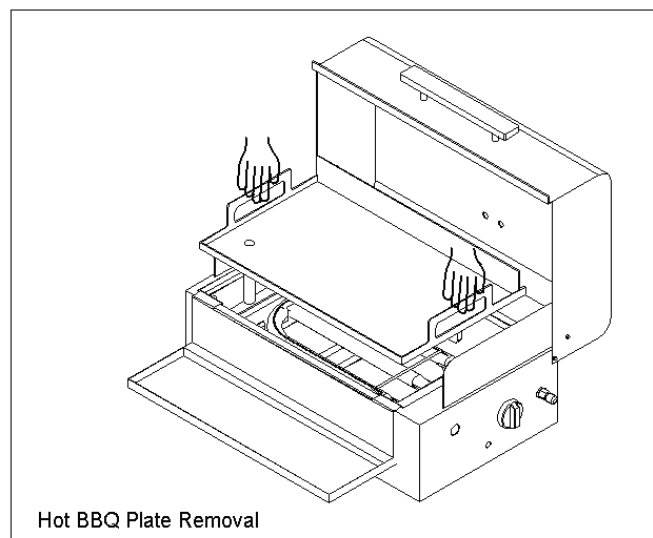

Recommended Cleaning Solutions and Appliances

Clean the inside and outside of your BBQ with warm soapy water as required. A stainless steel polish (such as “3M stainless steel cleaner and polish”) should be used at regular intervals to protect and shine the outer casing.

Cleaning your BBQ after each use will diminish the burden of removing stubborn build ups or deposits.

NEVER use abrasive materials (e.g. scouring pads) to clean the outside of your BBQ, this will scratch the appliance. A scouring pad may however be necessary to remove grease and build up on the BBQ Plate itself. Do not use caustic cleaners.

NEVER use steel wool, in addition to scratching it will also leave fragments that will rust.

Fat Tray and Flame Dispenser

WARNING: Cleaning the Fat Tray and Flame Dispenser (Flame Dispensers are supplied only with Flat/Grill model BBQs) after every use reduces the possibility of a fat fire in the fat tray caused by a flare-up. A flare-up is when fat from food drops onto the hot flame dispenser and ignites. A small amount of fat will quickly burn out. Removing excess fat from foods before cooking will reduce flare-ups (Be aware that some sausages can produce excessive fat during cooking). The only recommended lining for the fat tray is aluminium foil.

Burner Removal

Burners should be removed periodically and cleaned with warm soapy water. Ensure the burner is totally dry before reassembly, which may take some time (preferably dry your burner in the sun, but exercise caution as it may become very hot to touch).

To remove the burners:

Alpha Model (U-Shaped Burner)

- (1) Unclip the Piezo ignition system (the black cable with the ceramic pin end) by lifting it out of its securing bracket. Likewise, unbolt the thermocouple (copper tube with probe end, adjacent the Piezo lead) securing nut on the face side of the thermocouple locator bracket to allow the burner to slide out (the second rear nut, at the back of the thermocouple locator bracket, can be left as is).
- (2) Lift the left end of the burner up while holding back the securing clip.
- (3) Slide to the left, off the gas control valve and out of the thermocouple locator, and lift out.

Bravo Model (In-line Burner)

- (1) Unclip the Piezo ignition system (the black cable with the ceramic pin end) by lifting it out of its securing bracket.
- (2) Unscrew fixing on left hand side of burner.
- (3) Lift the left side of the burner and slide to the left.

The below diagrams will assist you in removing the burner from your selected Sovereign BBQ.

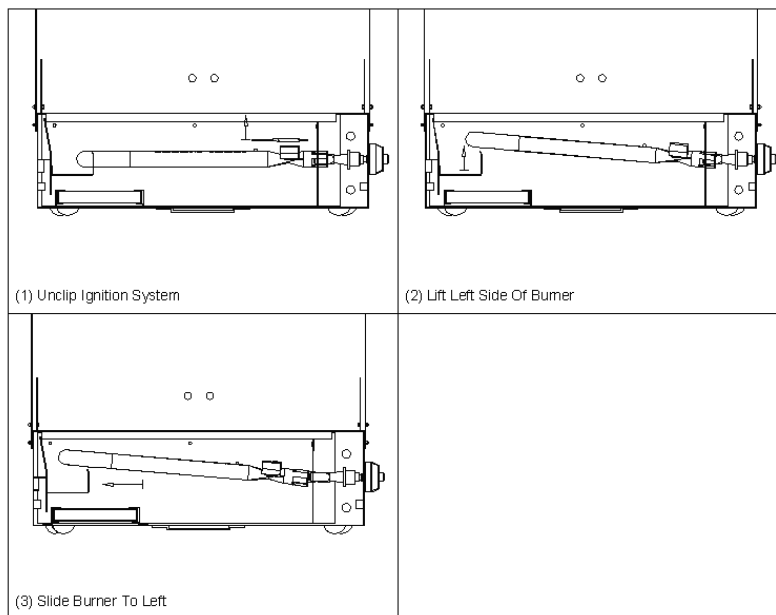

Ancillary Service Information

Your BBQ should be serviced at 12 month intervals (or sooner as required) by an authorised gas technician to ensure its ongoing safe operation. Note that the burner (flame) should always burn blue with only a small amount of yellow at the peak. If abnormal gas smells are present, turn off all controls and the gas supply point, then have your BBQ checked immediately by a qualified gas technician.

Do not modify this appliance in any way.

Sovereign BBQs & Grills Australia
Phone (Intl +61 7) 3382 0230 • Fax (Intl +61 7) 3382 0087
Web: www.sovereignbbqs.com • Email: sales@sovereignbbqs.com

WARNINGS

- (1) Your Sovereign BBQ is only to be used outdoors.
- (2) Read the “Installation and Operating Instructions” carefully before using the appliance.

DISCLAIMER

The “Installation and Operating Instructions” are provided on the understanding that: Sovereign BBQs are not responsible for the results of any actions taken relying on the information in these Installation and Operating Instructions, or for any error in or omission from these Installation and Operating Instructions. Please also review the comprehensive “Disclaimer” documentation as included with this paperwork, as use of the appliance infers your consent to this notification.